

Specification

FOR

Non-Metal Optic Cable

[ADSS-80M]

1. CABLE CONSTRUCTION

1.1. CROSS SECTIONAL DIAGRAM

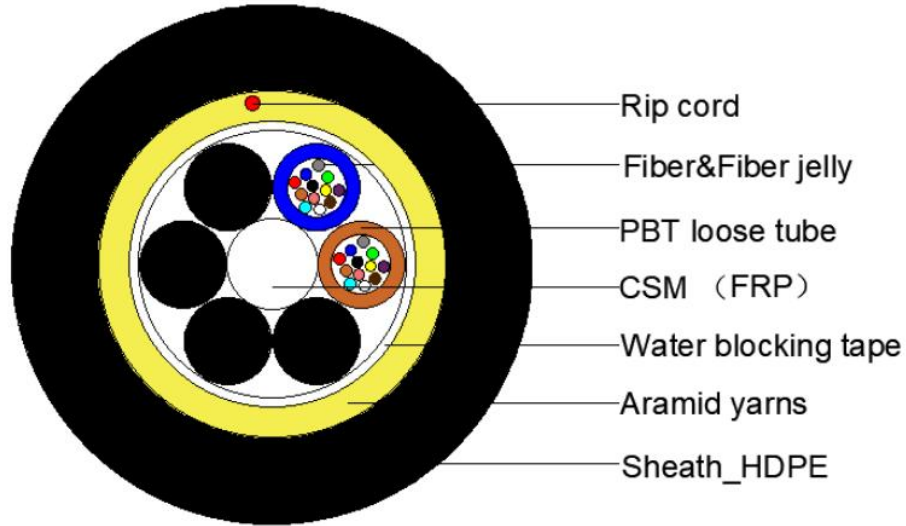

2. TECHNICAL SPECIFICATION

2.1. TECHNICAL SPECIFICATION

Fiber count	16F	24F
OD of Loose tube (mm)	2.2±0.1	
Max fiber count/tube	8	12
NO. of Tube	2	
NO. of Filler	4	
FRP/Coat (mm)	2.5	
Water blocking material	Water blocking tape/yarn	
Reinforced materials	Aramid yarn	
MDPE sheath Thickness (mm)	1.6	
OD of cable (mm)	10.5±0.25	
Net weight (kg/km)	88	
RTS (N)	5000	
MAT (N)	2000	

2.2 TEMPERATURE RANGE

Operating temperature	-40°C~+60°C
Store/Transport temperature	-50°C~+70°C
Installation temperature	-20°C~+60°C

3. FIBER AND LOOSE BUFFER TUBE IDENTIFICATION

NO.	1	2										
Tube Color	Blue	Orange										
NO.	1	2	3	4	5	6	7	8	9	10	11	12
Fiber Color	Blue	Orange	Green	Brown	Slate	White	Red	Black	Yellow	Violet	Pink	Aqua

4. OPTICAL FIBER

4.1 The Optical and Geometrical Performance of Single Mode Fiber (ITU-T G652D)

Items	UNITS	SPECIFICATION
Fiber type	-	G652D
Attenuation	dB/km	≤ 0.35 at 1310nm ≤ 0.22 at 1550nm ≤ 0.35 at 1625nm
Chromatic Dispersion	ps/nm.km	≤ 3.5 at 1310nm ≤ 20 at 1550nm ≤ 22 at 1625nm
Zero Dispersion Slope	ps/nm ² .km	0.093
Zero Dispersion Wavelength	nm	1300 ~ 1324
PMD (M=20, Q=0.01%)	ps/√km	≤ 0.2
Cut-off Wavelength (λ_{cc})	nm	≤ 1260
Attenuation vs. Bending (60mm x100turns)	dB	≤ 0.1 at 1625nm
Mode Field Diameter@1310nm	μm	$(8.6-9.5) \pm 0.7$
Core-Clad Concentricity	μm	≤ 0.5
Cladding Diameter	μm	125 ± 1
Cladding Non-circularity	%	≤ 0.8
Coating Diameter	μm	245 ± 5
Proof Test	Gpa	≥ 0.70
Temperature Dependence	dB	≤ 0.5 (-60°C to +85°C)

5. Mechanical and Environmental Performance of the Cable

NO.	ITEMS	TEST METHOD	ACCEPTANCE CRITERIA
1	Tensile Loading Test	#Test method:IEC 60794-1-E1 -. Long-tensile load: 0.5*MAT -. Short-tensile load: MAT -. Cable length: $\geq 50\text{m}$	-. Attenuation increment@1550nm: $\leq 0.1\text{dB}$ -. No jacket cracking and fiber breakage
2	Crush Resistance Test	#Test method:IEC 60794-1-E3 -.Long load: 500 N/100mm -.Short load: 1000 N/100mm Load time: 1 minutes	-. Attenuation increment@1550nm: $\leq 0.1\text{dB}$ -. No jacket cracking and fiber breakage
3	Impact Resistance Test	#Test method:IEC 60794-1-E4 -.Impact height: 1 m -.Impact weigh: 450 g -.Impact point: ≥ 5 -.Impact frequency: $\geq 3/\text{point}$	-. Attenuation increment@1550nm: $\leq 0.1\text{dB}$ -. No jacket cracking and fiber breakage
4	Repeated Bending	#Test method:IEC 60794-1-E6 -.Mandrel diameter: 20D (D = cable diameter) -.Subject weight: 15kg -.Bending frequency: 30 times -.Bending speed: 2s/time	-. Attenuation increment@1550nm: $\leq 0.1\text{dB}$ -. No jacket cracking and fiber breakage
5	Torsion Test	#Test method:IEC 60794-1-E7 -.Length: 1m -.Subject weight:25kg -.Angle: ± 180 degree -.Frequency: $\geq 10/\text{point}$	-. Attenuation increment@1550nm: $\leq 0.1\text{dB}$ -. No jacket cracking and fiber breakage
6	Water Penetration Test	#Test method:IEC 60794-1-F5B -.Height of pressure head: 1m -.Length of specimen: 3m -.Test time: 24 hours	-. No leakage through the open cable end
7	Temperature Cycling Test	#Test method:IEC 60794-1-F1 -.Temperature steps: $+20^{\circ}\text{C}$ 、 -40°C 、 $+70^{\circ}\text{C}$ 、 $+20^{\circ}\text{C}$ -.Testing Time: 24 hours/step -.Cycle index: 2	-. Attenuation increment@1550nm: $\leq 0.1\text{dB}$ -. No jacket cracking and fiber breakage
8	Drop Performance	#Test method:IEC 60794-1-E14 -.Testing length: 30cm -.Temperature range: $70 \pm 2^{\circ}\text{C}$ -.Testing Time: 24 hours	-. No filling compound drop out

5.2 FIBER OPTIC CABLE BENDING RADIUS

Static bending: ≥ 15 times than cable out diameter

Dynamic bending: ≥ 25 times than cable out diameter.

6. PACKAGE AND MARK

6.1 PACKAGE

Not allowed two length units of cable in one drum, two ends should be sealed,. Two ends should be packed inside drum, reserve length of cable not less than 3 meters.

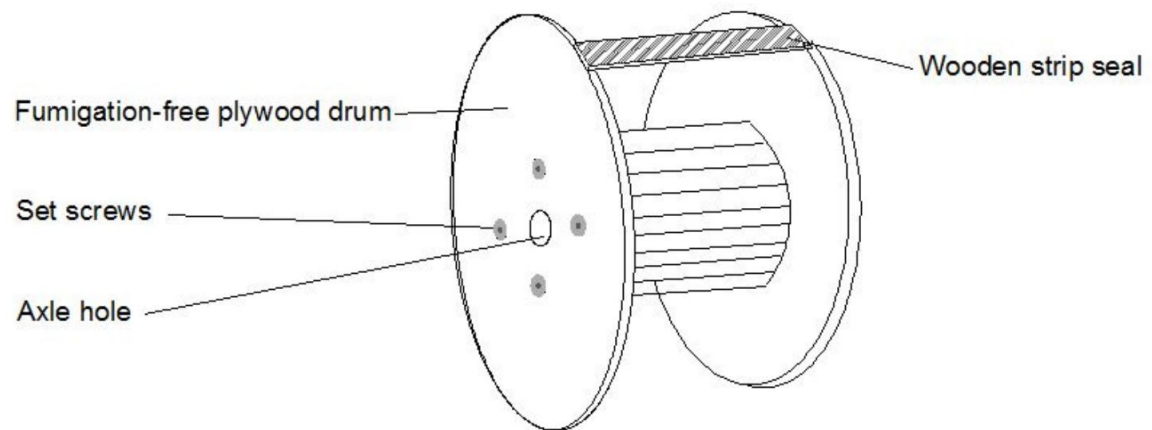

6.2 MARK

Cable shall be permanently marked in English at regular intervals with the following information

- a. Name of products
- b. Type of cable
- c. Fiber category

6.3 TEST REPORT

Test report and certification supplied.